

MODEL CS325B ASPHALT ROLLING
THIN FILM OVEN

OPERATING INSTRUCTIONS

JAMES COX AND SONS, INC.

1085 Alpine Way

P.O. Box 674

Colfax, CA 95713

ph: (530) 346-8322

fax: (530) 346-6854

Web Site: jamescoxandsons.com

3.	Model CS325B
4.	Important Precautions
5.	Getting Started: Electrical and Air Requirements
6.	Operating Instructions
7.	System Checks: 1) Air Regulator 2) Temperature Control 3) Flow Meter Calibration 4) Air Nozzle 5) Moisture Indicator
8.	Control Panel Layout-Front Fig.1
9.	Control Panel Layout-Back Fig.2
10.	Controller Programming
11.	Control Program, Factory Preset (Red Lion Controller)
12.	Control Program, Factory Preset (Delta Controller)
13.	ASTM Spec D 2872-97
14.	Parts List
16.	Electrical Schematic 60Hz Fig.6a (Red Lion Controller)
17.	Electrical Schematic 60Hz Fig.6b (Delta Controller)
18.	Electrical Schematic 50Hz Fig.7
19.	Motor Control Settings 50Hz Fig.8
20.	Air Schematic Fig.9
21.	Flow Meter Calibration Chart
22.	Dry Air System Schematic Fig.10
23.	Troubleshooting
24.	F.A.Q. (Frequently Asked Questions)
25.	Calibration

26.

Warranty

MODEL CS325B ASPHALT ROLLING THIN FILM

OVEN

The Model CS325B Precision oven is designed for the specific requirements of the Asphalt Rolling Thin Film Tests as specified in *State of California Test Method 346-E*, *AASHTO T-240* and *ASTM D2872*.

Repeatability of the aforementioned test is directly related to the accuracy with which the oven temperature can be maintained to the specified standard temperature of 325° F (163° C), and the reproducibility of the thermal rise-time of the system within the time period allocated from load time to assumed equilibrium of the system. The CS325B has been designed to optimize the precision of performance with regard to maintenance of set point while attaining high-speed recovery from thermal disturbances caused by reloading.

The oven temperature is sampled by a precision sensor exposed to the supervised environment at a location which is representative of the desired specimen location. The thermal mass of the sensor is extremely low, having a thermal/electrical time constant measurable in seconds.

The system is a fully stabilized closed loop thermal/electrical feedback control system. The system has fast response, tight control limits and freedom from overshoot. There are no mechanical relays, contactors, commutators, mechanically operated or thermal-pressure magnetic devices utilized. The entire system is fully electronic, noiseless and non-mechanical in nature. There is nothing to wear or fatigue. High speed of response is assured by complete control of a 3000 watt heating element. Thermal conduction and radiation losses are low and virtually all applied power is consumed in replacing losses due to the air vents required for dissipation of expended volatile from the specimens.

Every precaution has been taken in the preparation of this publication. Cox & sons assumes no responsibility for errors or omissions. Neither is any liability assumed for damages resulting from use of the information contained herein.

IMPORTANT PRECAUTIONS

1. Do not open door with blower or rack-motor on.
2. Disconnect oven power supply at source when working inside the cabinet to avoid electrical shock.
3. Turn sample rack with control button to prevent damage to gear reducer.
4. The air nozzle will cause breakage if the sample containers are not placed firmly against the rack backstop.

ELECTRICAL REQUIREMENTS

Electrical: Maximum load, 2 KVA. Power factor, 0.90.
3000 Watt heating element.

Standard: 208 - 240 VAC, 60 Cycle, single phase. 3 Wire grounded neutral.

Optional: 220 VAC, 50 Cycle, single phase.

Thermal Protection: Electrical circuits fully protected by temperature switch and fuses in both legs. The thermal protection on the switch is 425° F.

The switch allows the heat to shut down at 425° F and turn back on at 375° F repeatedly until the problem is resolved.

For electrical schematics see page 16, Fig.6a for the Red Lion Controller, page 17 Fig. 6b for the Delta Controller or page 18, Fig.7 for the 50Hz schematic.

AIR REQUIREMENTS

Air System Requirements:

- a) Air supply to this unit should not exceed 125 PSI
- b) Supply dry clean air. See page 20, Fig.9 for example
- c) If air supply is contaminated, install an air filter
- d) If moisture or oil fumes are present, install a dehydrator

OPERATING INSTRUCTIONS

Step 1: Push Power Button

Push Power Blower and Sample Rack Buttons.

Step 2: Set air pressure by using pressure regulator knob. Pull Knob out to release lock. Turn until it reads 50 PSI on pressure gauge. Push knob to re-lock. Set air flow tube by using flow meter control knob, turning counter-clockwise. Bring ball up to the calibrated set point.

See page 21.

Step 3: Allow oven to come up to temperature and stabilize at 163° C.

Oven is now ready to install test samples. Turn blower and sample rack off, leaving power button on. Put bottles in rack, close door and turn on blower and sample rack. Oven will return to 163° C in 10 minutes. The test should be performed following the AASHTO T-240 and ASTM D2872 procedures. See page 13 ASTM Specification information.

NOTE: Your oven temperature controller has been programmed at our facility to perform applicable tests. You should not need to change any controller settings, if you do need to adjust temperature refer to page 10.

CONTROL PANEL-SYSTEM CHECKS

- 1) Air Regulator: Setpoint 50 PSI.
- 2) Temperature Control: The control is programmed for the required thermal rising time and the 163° C setpoint as required by the rolling thin film test. The only adjustment that may be necessary is a slight change in the temperature setpoint. Refer to page 10, “Controller Programming”, steps 4 & 5
- 3) Flow Meter Calibration: The air flow rate of 4000ml should be measured at the outlet nozzle by a suitable method. The oven should be at room temperature and correction made to standard conditions of barometric pressure and temperature. This measurement should be checked periodically. See page 21 for chart
- 4) Air Nozzle:
 - a) Clean with No. 60 twist drill.
 - b) Use the shank end of the drill to prevent enlarging the orifice.
- 5) Moisture Indicator:
 - a) Contains color-changing blue silica gel;
 - dry air-blue
 - moist air-pale pink
 - b) The indicator reactivates itself when dry air flows through it. However, in time it may lose this quality and it would be necessary to replace the silica gel.

CONTROL PANEL LAYOUT FRONT

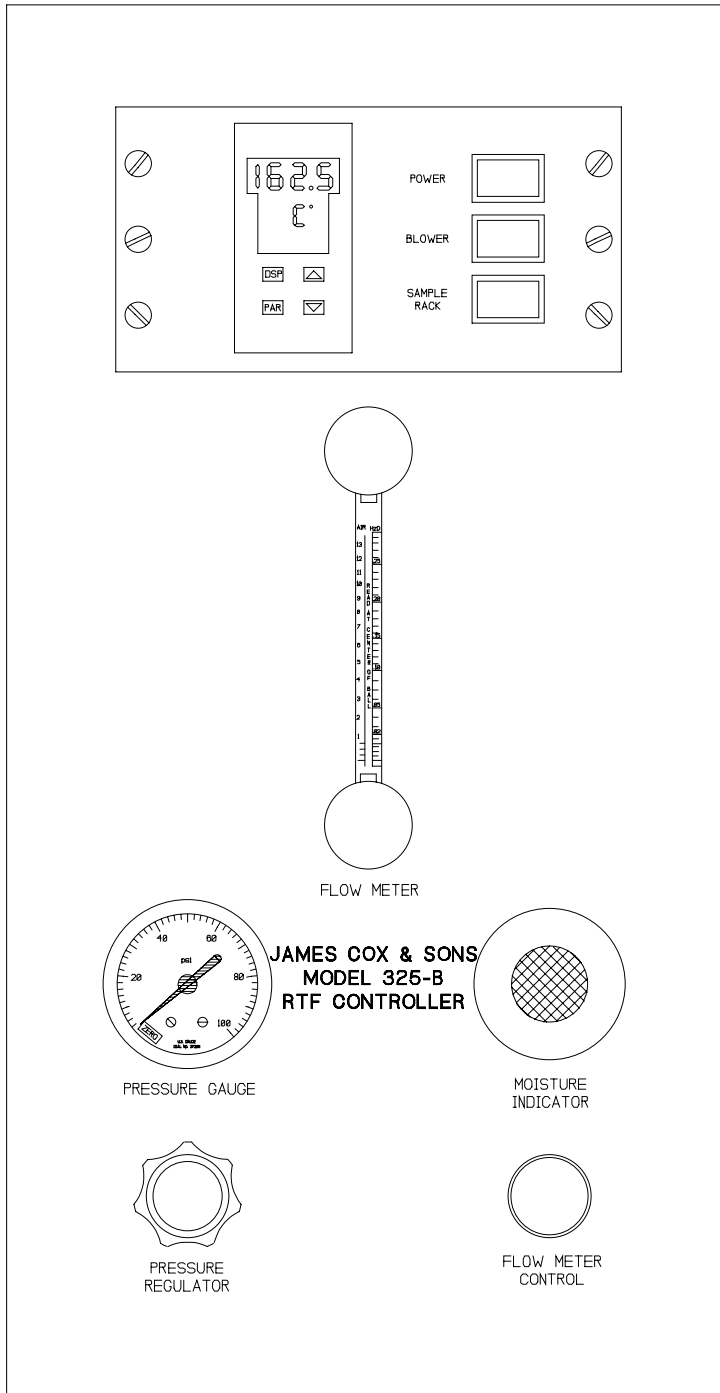

Fig. 1

CONTROL PANEL LAYOUT

BACK

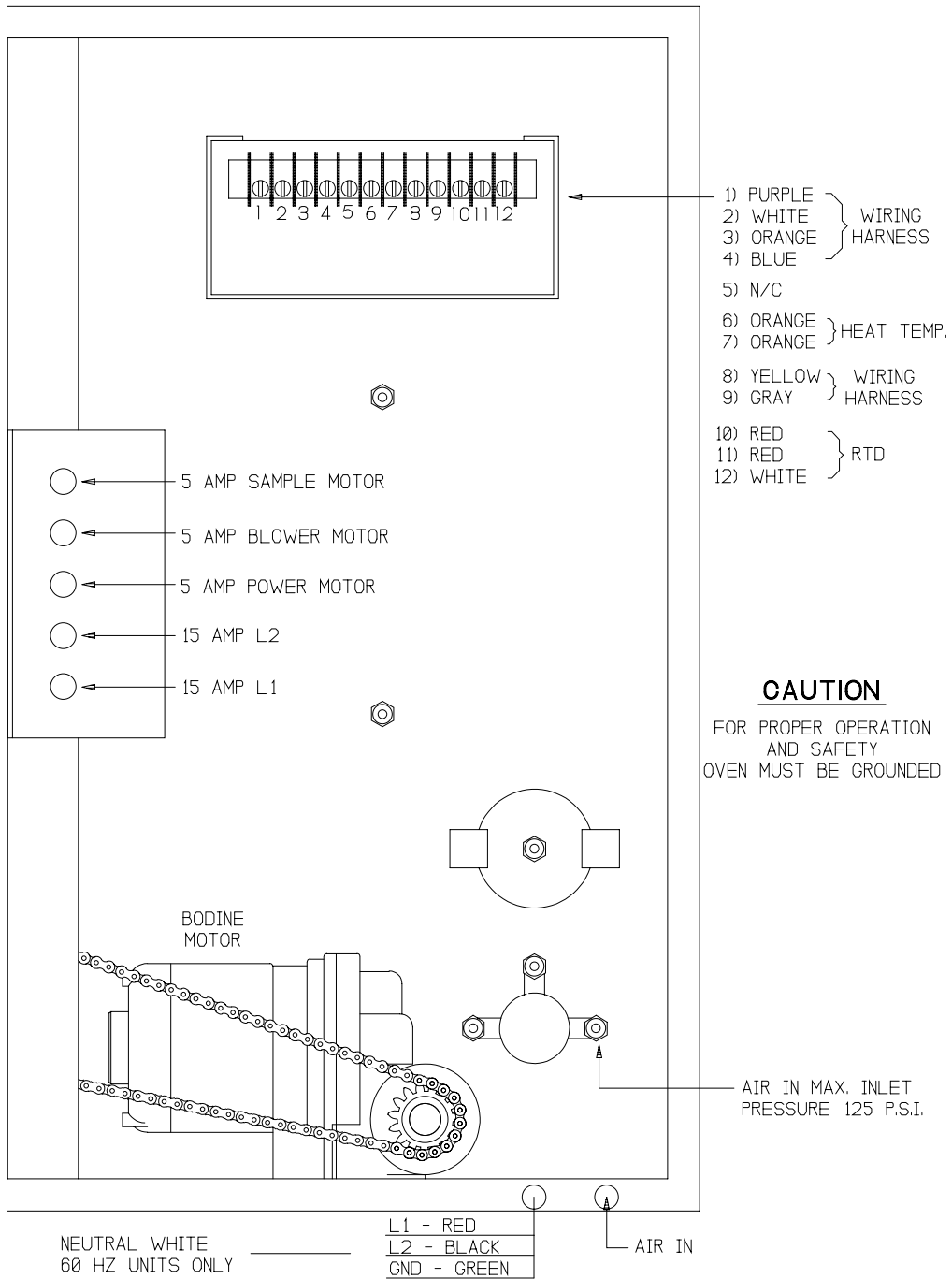

Fig. 2

CONTROLLER PROGRAMMING

Step 1: To enter into program A.

Push the PAR button once, this puts you into program A.

Step 2: To enter into program 1, 2, or 3.

For instance, you want program 2, you press PAR button four times, the control will then flash “CNFP” or “NO” on screen. At this point you need to press the UP button on the controller two times, which puts you into program 2. If you want to program 3, press the UP button three times.

Step 3: Programming the 1, 2, or 3.

For instance, if programming is needed to program 2; after entering into program 2, press the PAR button once, twice, three times, etc., until required letters appear on the screen. Press the UP or DOWN button to obtain the correct number needed.

Press the PAR button repeatedly until “CNFP” or “NO” flashes on the screen. At this point, press the UP or DOWN button to enter in another program and repeat procedure or press PAR button when “CNFP” or “NO” is on screen. When the program is complete, “END” will appear on the screen; the controller will then display “TEMP”.

TEMPERATURE ADJUSTMENT

Step 4: After the oven has been running and temperature is stabilized on controller, make a comparison to an ASTM thermometer. If there is a difference, you need to enter program 1. After entering program 1, press the PAR button six times. SHFE should appear on the screen. At this time you would press the UP or DOWN button depending on the oven temperature; UP to cool and DOWN to heat.

Step 5: To end procedure, press the PAR button until “CNFP” or “NO” appears on the screen. Press PAR once again, “END” will appear and controller will return to normal display.

CONTROL PANEL PROGRAM FACTORY PRESET
RED LION CONTROL

A	PROP	Proportional Band	0.5
	INTT	Integral Time	155
	DERT	Derivative Time	5
	(CNFP or NO)		

1	1-In	Input Module	
	TYPE	Input Sensor Type	R385
	SCAL	Temp. Scale Units	°C
	DEPE	Decimal Places	0.0
	FLtr	Input Signal Filter and Display update Rate	1
	SPAN	Input Slope	1.000
	* SHFT	Input Offset	±
	SPLO	Setpoint Limit Value Low	50.0
	SPHI	Setpoint Limit Value High	200.00
	SPrP	Setpoint Ramp Rate	800

2	2-OP	Output Module	
		Access Output Power	
	CYct	Time Proportioning Cycle Time	1
	OPAC	Output Control Action	REV
	OPLO	Output Power Limits Low	0
	OPHI	Output Power Limits High	90
	OPFL	Sensor Fail Preset Power	0
	OPdP	Output Power Dampening	1
	CHYS	On/Off Control Hysteresis Band ...	1
	tcod	Auto-Tune Dampening Code	4

3	3-LC	Lockouts Module	
		Lower Display Lockouts (SP , OP, dEv, UdSP)	
	SP	Setpoint Value	Ent
	OP	% Output Power	Ent
	dEv	Setpoint Deviation	rEd
	UdSP	Temperature Units	rEd
		Protected Mode Lockouts (Code, PID)	
	CODE	Access Code Number (0-250)	0
	PID	Permits access to main PID parameters ..	Ent
		Hidden Mode Lockouts (trnF, tUNE)	
	trnF	Select Automatic or Manual operation ...	LOC
	tUNE	Invoke or cancel Auto-Tune	LOC

CONTROL PANEL PROGRAM
FACTORY PRESET

DELTA CONTROL

REGULATION MODE	OPERATION MODE	INITIAL SETTINGS
AT=OFF	R-5=RUN	CNPT=PT
PCDO=0.0	SP=1	TPUN=C
PID _____SUO	LOC=?	TP-H=200
PO=5.5	OUT1- locks all settings	TP-L=10
CO=14	OUT2- locks all settings	CTRL=PID
DO=3	except temp up/down	5-HC=H2C1
COFO=0.0_____		ALA1=0
CLPd=1		ALA2=0
HCPD=2		SALA=OFF
COEF=1.50		COSH=OFF
DEAD=5		C-SL=ASC11
TPoF=offset value		C-NO=1
CRHC=12		BP5=9600
CRLO=0		LEN=7
		PRTY=EVEN
		STOP=1

The Delta control is set at the factory with the configuration settings locked out. The only setting that can be changed is the temperature. To unlock the control hold down the set button and the looped arrow button at the same time.

To change the offset press set button 1 time then press the looped arrow button 10 times. The red display will read TPOF, use the up or down arrow to change offset.

If the mercury thermometer reads higher than the display, raise the offset value using the up arrow. If the mercury thermometer reads less than the display, lower the offset valve by pressing the down arrow.

**Note:* The inside mercury thermometer will read approximately .5° lower than the digital thermometer when the sample rack is empty. The *SHFT* input offset should be configured with the sample jars are in the rack and that the oven has been operating for at least 2 hrs prior.

The ASTM SPEC D 2872-97 Standard Test Method for Effect of Heat and Air on a Moving Film of Asphalt (Rolling Thin-Film Oven Test) document can be obtained directly from ASTM International . They can be reached by the web at www.astm.org.

CS325B RTF OVEN PARTS LIST

<u>Item #</u>	<u>Item Description</u>	<u>Item #</u>	<u>Item Description</u>
325:01A	Bodine Rack Motor 60cycle	325:39	Thermometer
325:01B	Dayton Rack Motor 50cycle	325:40	Chain (please specify oven cycle)
325:02	Heating Coil	325:41	Transite Plate
325:03	Power Switch	325:42	Latch-Set Inside (1 set)
325:04	Sample Rack Switch	325:42A	Latch Housing
325:05	Blower Switch	325:43	DC Blower Motor
325:06		325:44	DC Motor Control
325:07	Sample Rack Assembly	325:45	Blower Safety Door Switch
325:08	Sample Rack Spindle Bushing (1 set)	325:46	
325:09	Blower Motor- 60 Cycle	325:47	
325:10	Blower Motor Flexible Coupling	325:48	Hi-Lo Sensor Thermistor
325:11	Blower Spindle Housing	325:49	Wiring Harness
325:12	Blower Shaft-3/8 Diameter	325:50	
325:13	Blower Bushings (1 set)	325:51A	Main RTD Sensor
325:14	Squirrel Cage	325:51B	RTD Sensor (Modification on late 95B Model)
325:15	Top Motor Mount	325:52	
325:16	Air Heating Copper Coil	325:53	Controller-Series B
325:17	Flow Meter	325:54	Plastic Micro Switch Cover (Red, Blue, Yellow)
325:18	Air Gauge	325:55	Jar Tongs
325:19	Flow Meter Adjustment Valve	325:56	Complete Oven Controller Includes : (Controller, Wiring Harness, Flow Meter, Air Gauge, Flow Valve, Air Regulator, RTD Control, Thermal Shut Down)
325:20	Bodine Rack Motor Bracket	325:57	Rebuild Oven Front Door
325:21	Air Regulator	325:58	
325:22	DC Motor Control Bracket	325:59	
325:23	SSR Cydom D2425	325:60	Control Card OMD-00003
325:24	DC Motor Control Adapter	325:61	CS325 Operations Manual
325:25	Main Temperature Controller	325:62	Dry Air System Complete
325:26	Sample Bottles-Clear	325:63	Precision Thermostat Switch Triax 2N6146 9 Shut Down)
325:27	Sample Bottles-Frosted	325:64	
325:28	Air Nozzle	325:65	Blank Front Panel
325:29	Sample Rack Shaft	325:86	Wilkerson Dryer Desiccant
325:30	Sample Rack Fingers-(set of 8)	325:87	Wilkerson Filter, Coalescing
325:31	Transformer	325:90	Wilkerson Air Line Filter
325:32	Rack Spindle Housing (bearings not included)	325:91	Wilkerson Separator Condensate
325:33A	Silicon Gasket for Door (per inch)	325:92	Gilmount Mass Flow Control
325:33B	Silicon Gasket for Door Glass (per inch)	325:93	SSR
325:35	Plastic Handle for Door		
325:36	Handle Assembly \ (includes plastic handle)		
325:37	Silica Gel 1-1/2 LB Can		
325:38	Pyrex Plate		

<u>Item #</u>	<u>Item Description</u>
325:94	Jar Cooling Rack
325:95	Bottle Scraper
325:96	Fuses
325:97	Oven Retrofit
325:98	Complete New Door
325:99	Flow Meter Calibration
325:100	Moisture Indicator Lens
325:101	Fuse Brackets
325:102	Flow Meter End Caps
325:129A	Bronze Thrust Bearing

ELECTRICAL SCHEMATIC
60 Hz ASPHALT OVEN
RED LION
CONTROLLER

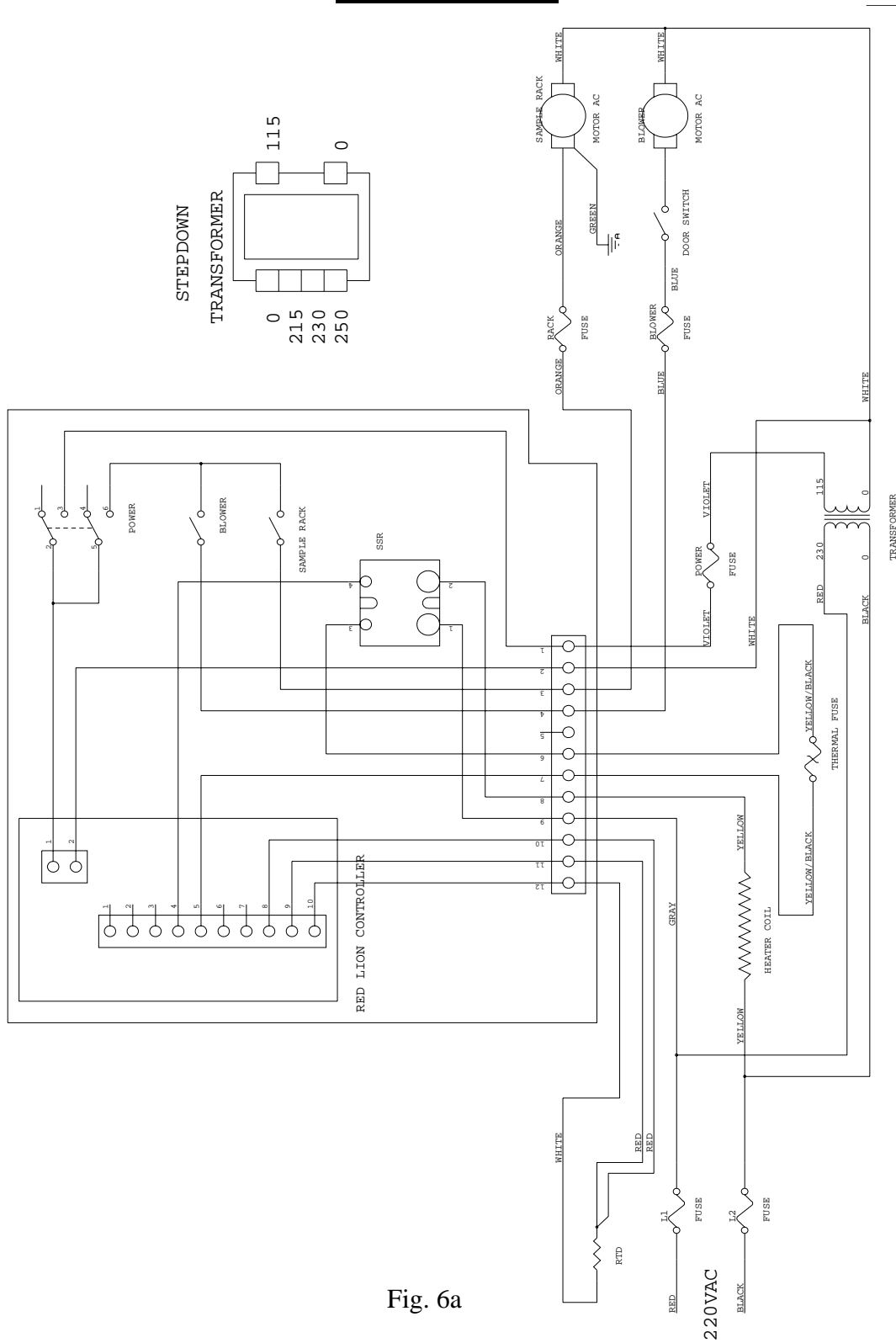

Fig. 6a

ELECTRICAL SCHEMATIC

60 Hz ASPHALT OVEN

DELTA

CONTROLLER

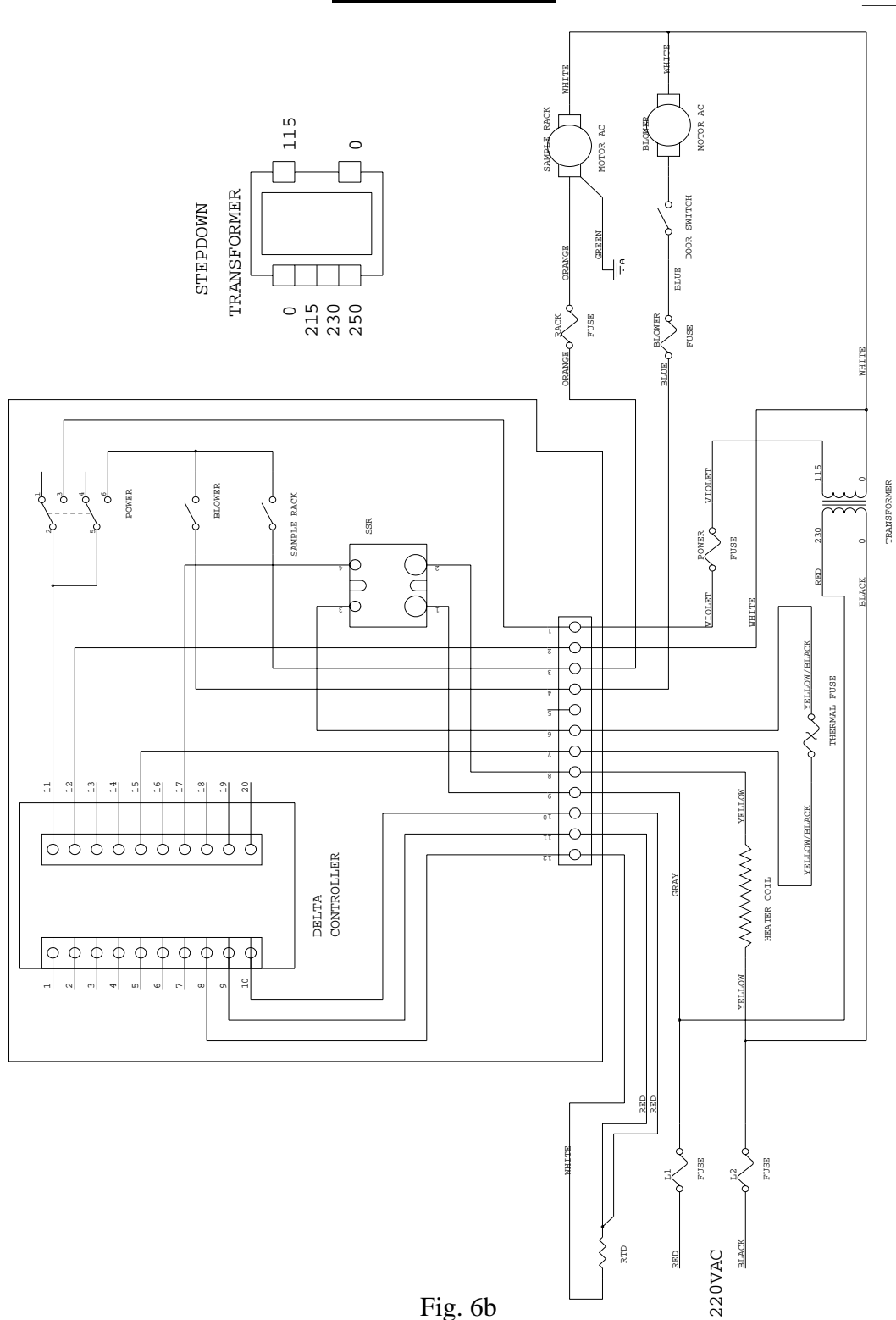

Fig. 6b

ELECTRICAL SCHEMATIC

50 Hz ASPHALT OVEN

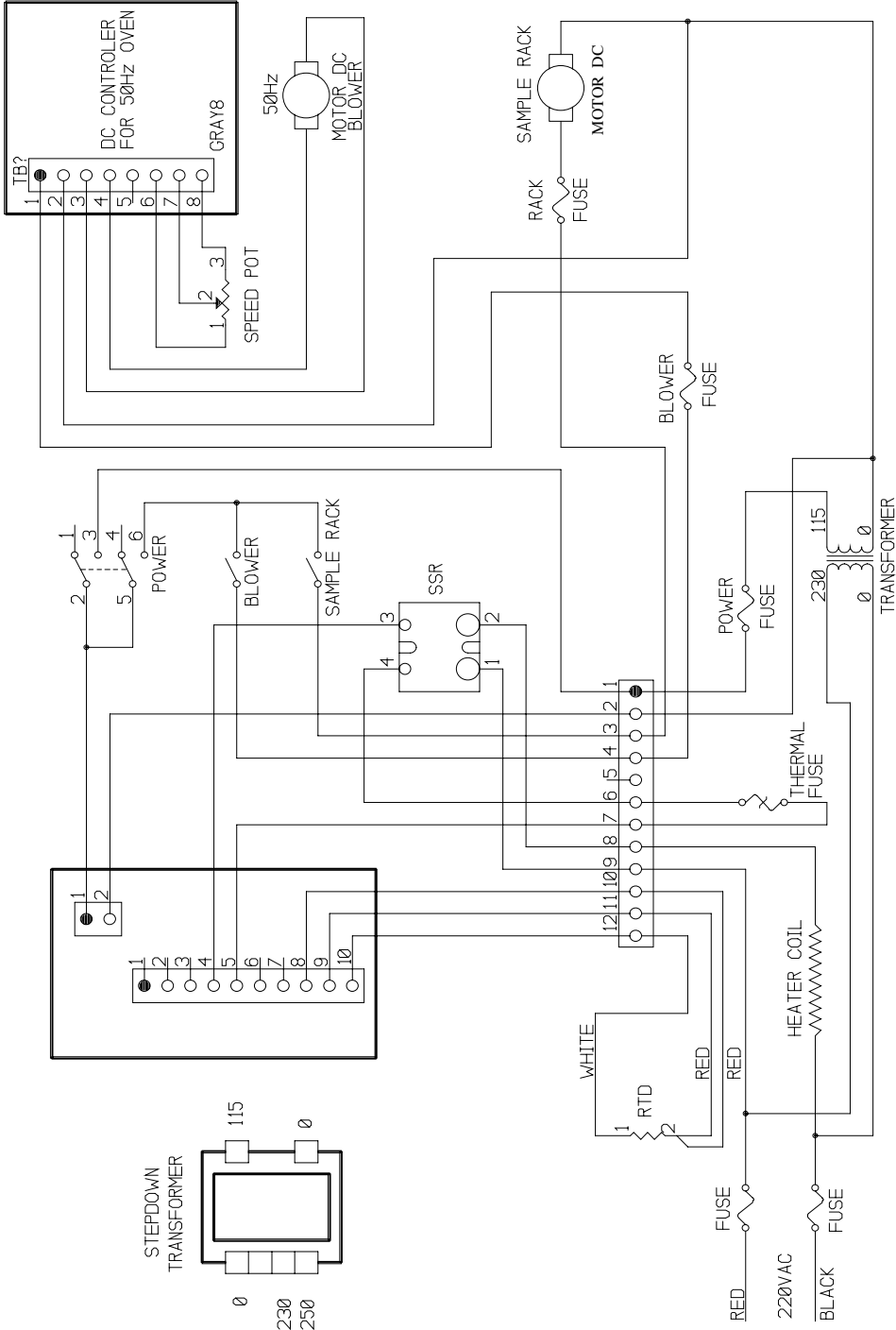

Fig. 7

MOTOR CONTROL
SETTINGS & LOCATION
50 Hz

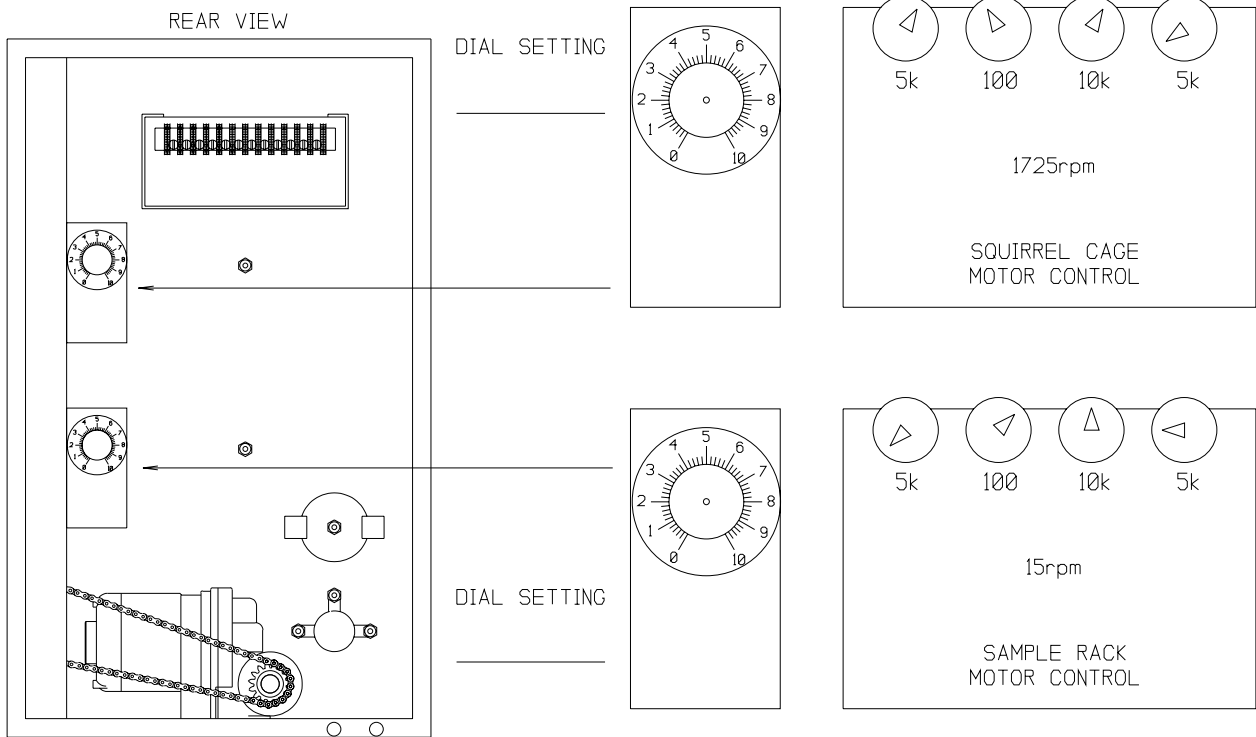

Fig. 8

AIR SCHEMATIC

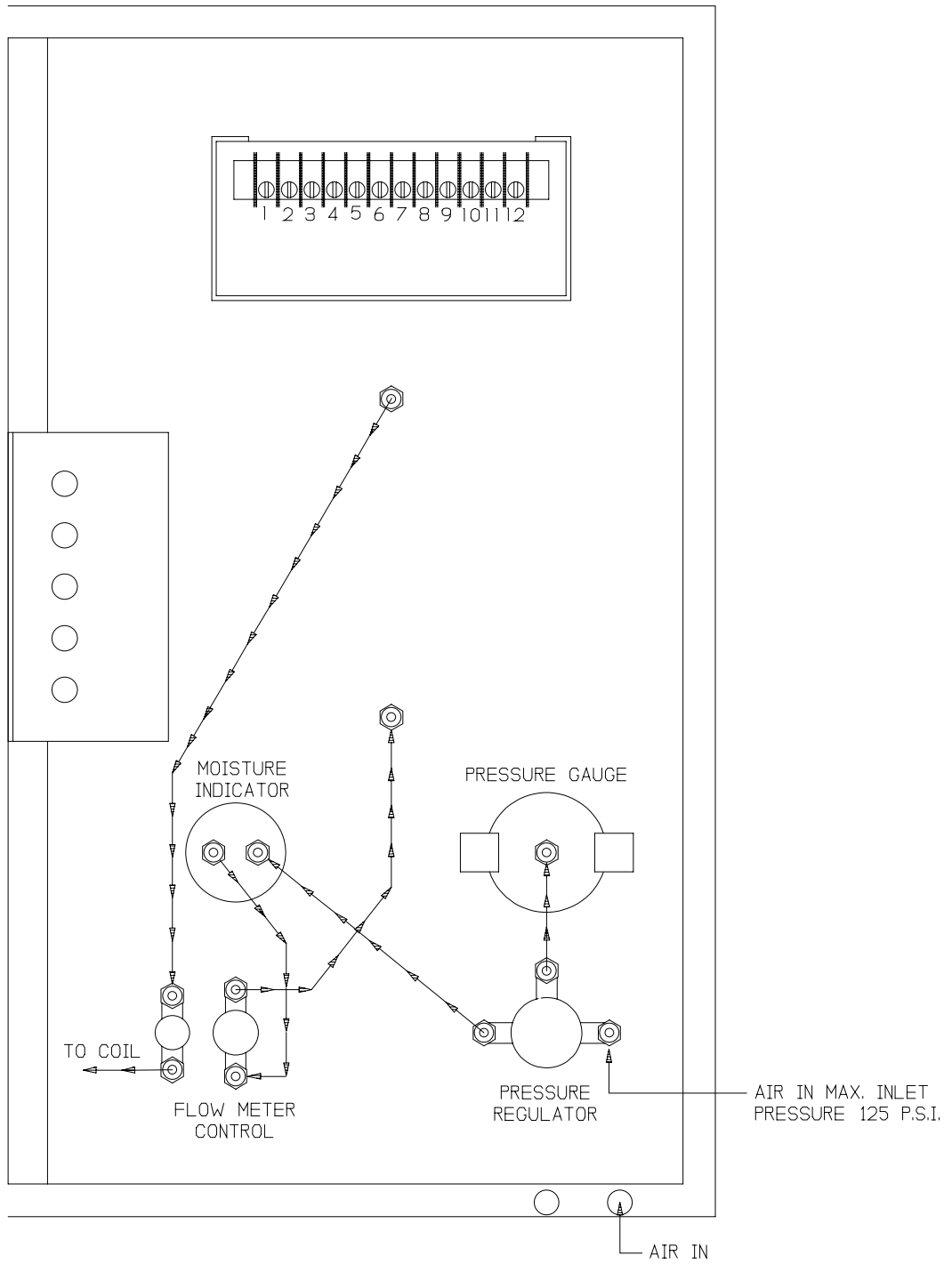
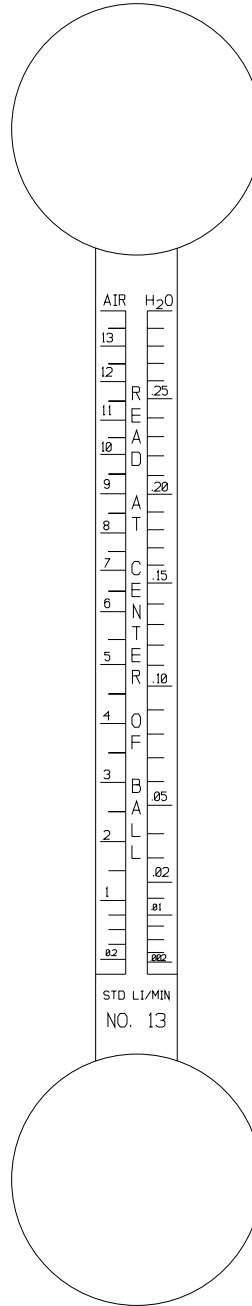

Fig. 9

FLOW METER CALIBRATION



OVEN MODEL# _____

SERIAL# _____

Date of Calibration _____

ADJUST CENTER OF BALL TO _____ ON FLOW METER THIS
WILL EQUAL A CALIBRATED FLOW FOR 4000 ML.

DRY AIR SYSTEM

AS NEEDED - CAN BE SUPPLIED BY CUSTOMER
OR PURCHASED FROM MANUFACTURE
FOR PRICE CONTACT SALES

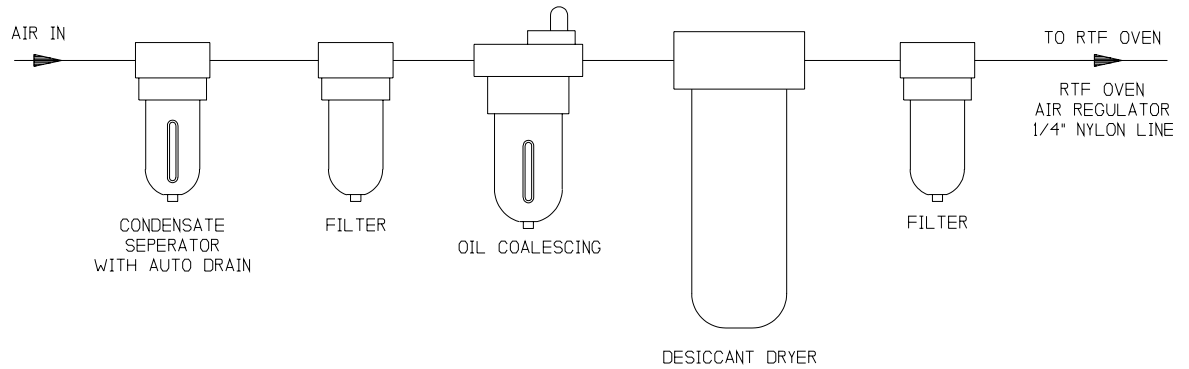

Fig. 10

DRY AIR SYSTEM PARTS LIST

ORDER # - PART

325:DA1 Condensate Separator
325:DA2 Filter
325:DA3 Oil Coalescing
325:DA4 Desiccant Dryer

Troubleshooting

In Case of apparent malfunction, please check the following points first.

1. Noisy Rack Motor ?
Check chain for adjustment, the Sprocket on the Rack may be tight (adjust to .020), or you may have a bad motor.
2. Noisy Blower Motor ?
Check Graphite Bushings (they may be worn), Squirrel cage may be out of balance or it needs to be tightened, Improper adjustment, Bad Motor.
3. Rack will not Turn ?
Bad Rack Motor, Check fuse, Sprocket is loose on Motor, Bad Rack Switch
4. Power on, but no Heat ?
Bad RTD Sensor, Bad connections to heating coils, Check Fuse, Bad Switch, Check for broken wire from RTD to Controller.
5. No Power to Oven ?
Check wiring from your service panel to oven, Check Fuses, In your User Manual, For electrical schematics see page 16, Fig.6a for the Red Lion Controller, page 17 Fig. 6b for the Delta Controller or page 18, Fig.7 for the 50Hz schematic.

F.A.Q.
Frequently Asked Questions

- | | |
|---|---|
| 1. Power Requirements ? | See Page 5 in the User Manual. |
| 2. What is the Max. Air Pressure ? | Air supply to this unit should not exceed 125 PSI, See Page 5 in the User Manual. |
| 3. What PSI should I set the Regulator to ? | Turn regulator until Pressure Gauge reads 50 PSI, See Page 5, 6 in the User Manual. |
| 4. Has the Flow Meter been Calibrated ? | Yes, to 4000ml we calibrate before shipping, See Page 21 in the User Manual. |
| 5. Do we offer On Site Service ? | Yes, Please call (530)346-8322 for On Site Service Quotation. |
| 6. Can I Mount a Hood Vent to Oven ? | Yes, as long s it doesn't Touch the oven or interfere with the performance of Oven. |
| 7. Witch RTD should I be using ? | See Page 23 in the User Manual. |

CALIBRATION

1. Temperature:

Our units are supplied with a digital readout. You need to have an ASTM Loss on Heat Thermometer positioned in the RTF Oven per *ASTM D 2872-97*. The thermometer must reflect the same temperature as the digital readout. The RTD in the digital readout will have a faster reacting time than the thermometer. Our units are preset at the factory. You may need to make some fine tuning adjustments as humidity, elevation, and room temperatures are factors in proper temperature settings.

2. Flow Meter:

We suggest using a Mass Flow meter for calibration of your flow meter. You can purchase these units from *Omega* at (1-800) 826-6342.

We use a Certified Omega Mass Flow Meter to calibrate our units prior to shipment. The Mass Flow Meter is returned to Omega annually for recertification.

The calibration standards used by Omega engineering are traceable to NIST or applicable international standards.

MIST reference #213426, 731 / 241140-88, 821 / 256363-96, 811 / 254335-94

We cannot issue NIST certification of calibration. Ours would be a secondary calibration.

3. Rack Rotation:

Our 60 cycle units are preset from the factory.

Our 50 cycle units use a variable DC Speed Control and the Rpm's of the Rack and Blower Motors require calibration on installation. You can purchase an optical tachometer from the Cole-Parmer Instrument Co. (1-800) 323-4340, catalog no. E-87500-10.

WARRANTY

James Cox & Sons, Inc. warrants all manufactured products to be free of mechanical and electrical defects in materials and workmanship for a period of one year from the date of acceptance by the purchaser. If the date of acceptance is unduly prolonged, the warranty period will automatically commence thirty (30) days from the date of delivery at the customer's site.

James Cox & Sons, Inc. will replace or repair free of charge, but not including transportation costs, installation or any other service charges, components or assemblies that are manufactured by us which our inspection reveals to be defective, provided they are returned to our plant within the warranty period. The warranty extends only to those products that have been assembled and installed according to our instructions or by a qualified service engineer. All standard components are covered under the same warranty. Other non-standard, major items which are not manufactured by us but have been requested by the customer as an addition to a standard unit will carry the remaining portion of the warranties of the original manufacturer.

This warranty does not cover normal wear of parts or damage resulting from any of the following: negligent use or misuse of the product, use on improper voltage or current, use contrary to operating instructions, or disassembly, repair or alteration by any person other than an authorized service engineer.

The terms of the warranty are revoked if any part or assembly is physically modified in any manner whatsoever by the customer or agency other than James Cox & Sons, Inc. without written permission.

Assistance agreements are available for products that require on-site repair. The agreements provide emergency service when deemed necessary by the customer. Tourist-class round trip airline transportation will be charged at cost, along with current daily rates for field service personnel.